

# HONDA

GX120K1 · GX160K1

## VALVE CLEARANCE

### NOTE

- Valve clearance inspection and adjustment must be performed with the engine cold.

1) Remove the four cylinder head cover bolt, cylinder head cover and gasket.

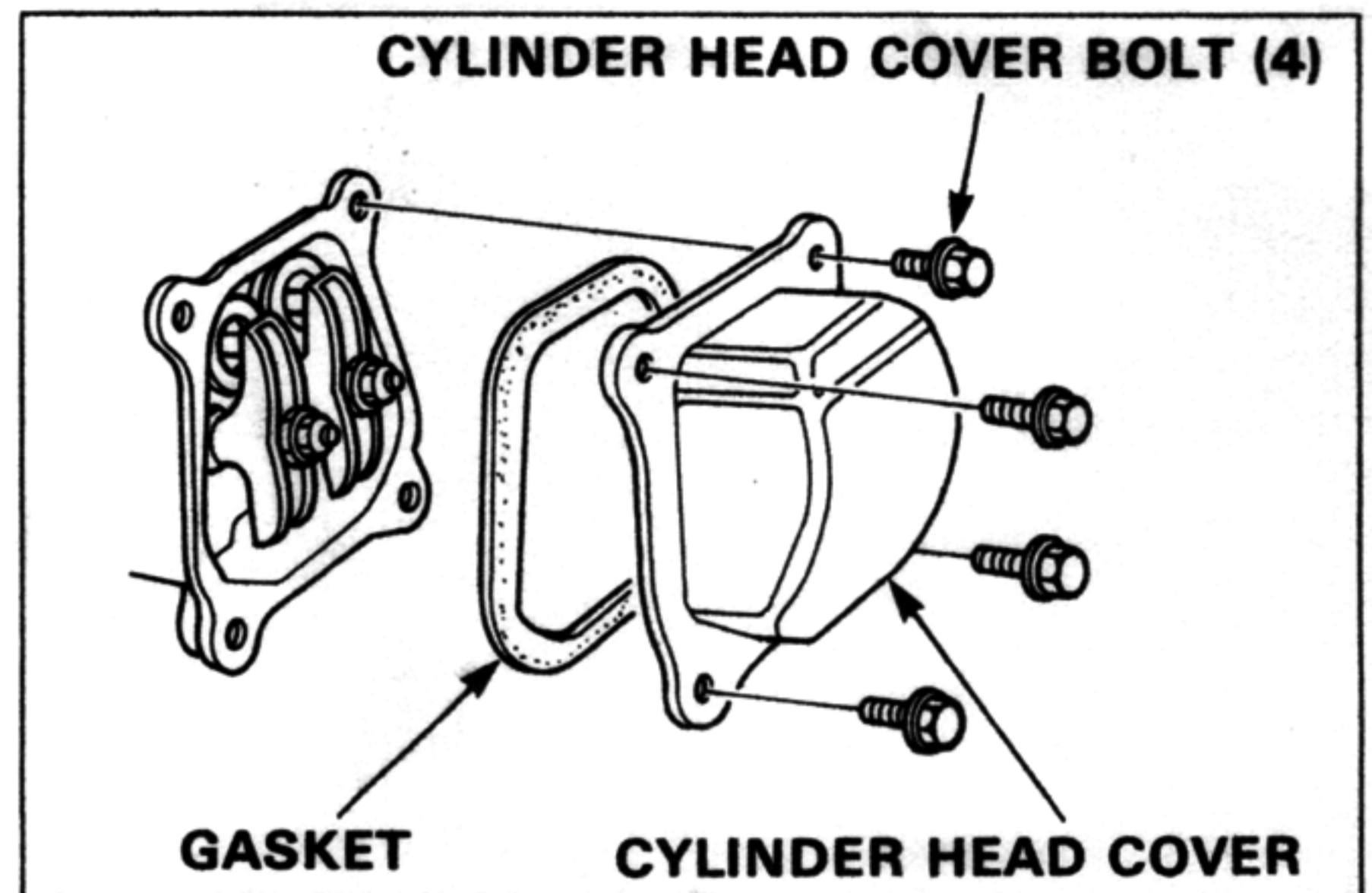

2) Set the piston at top dead center of the compression stroke (both valves fully closed). The triangular mark on the starter pulley will align with the top hole on the fan cover when the piston is at top dead center of the compression or exhaust stroke.

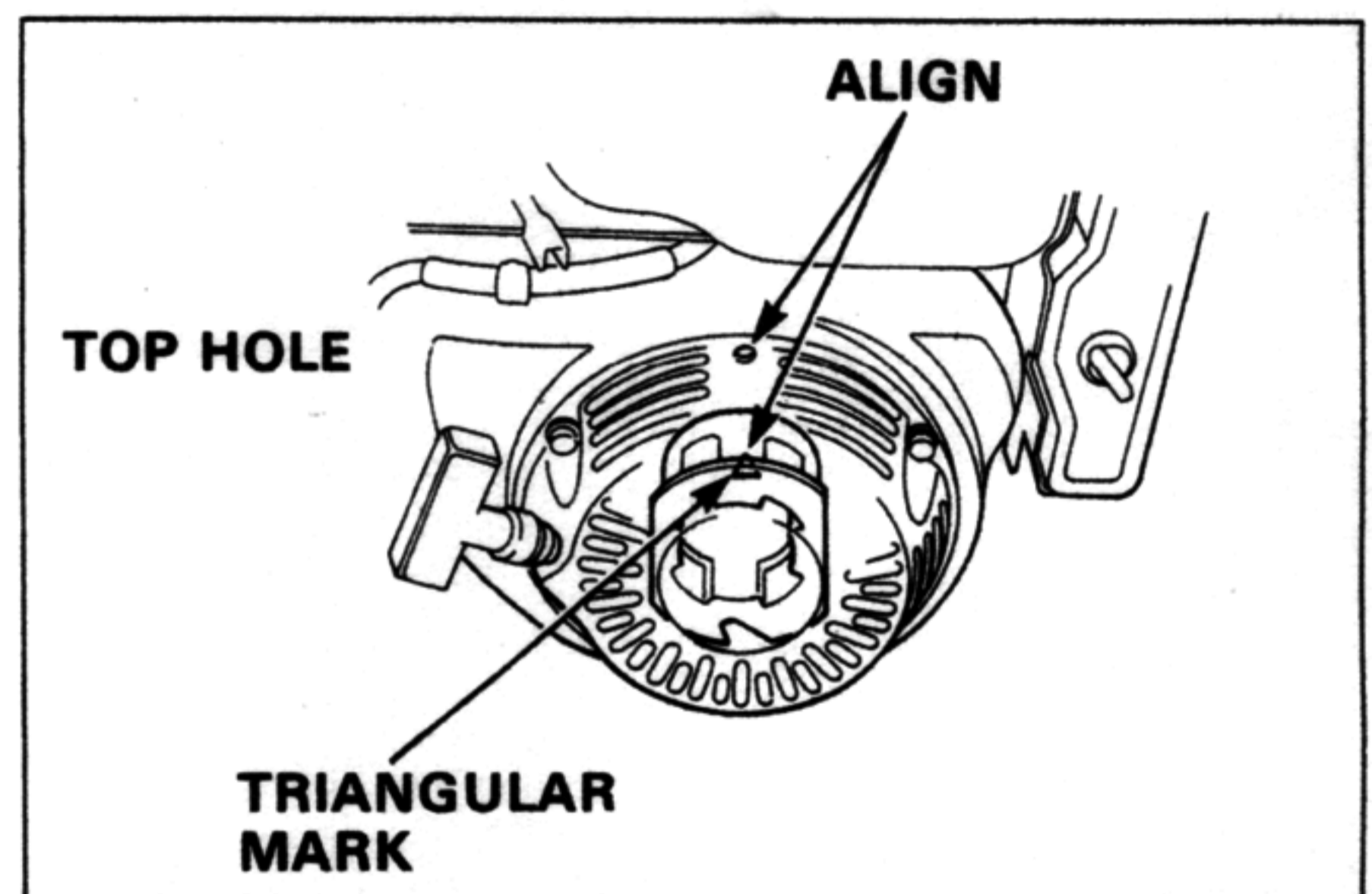

3) Insert a feeler gauge between the rocker arm and valve to measure valve clearance.

Standard valve clearance	IN	0.15±0.02 mm (0.006±0.001 in)
	EX	0.20±0.02 mm (0.008±0.001 in)

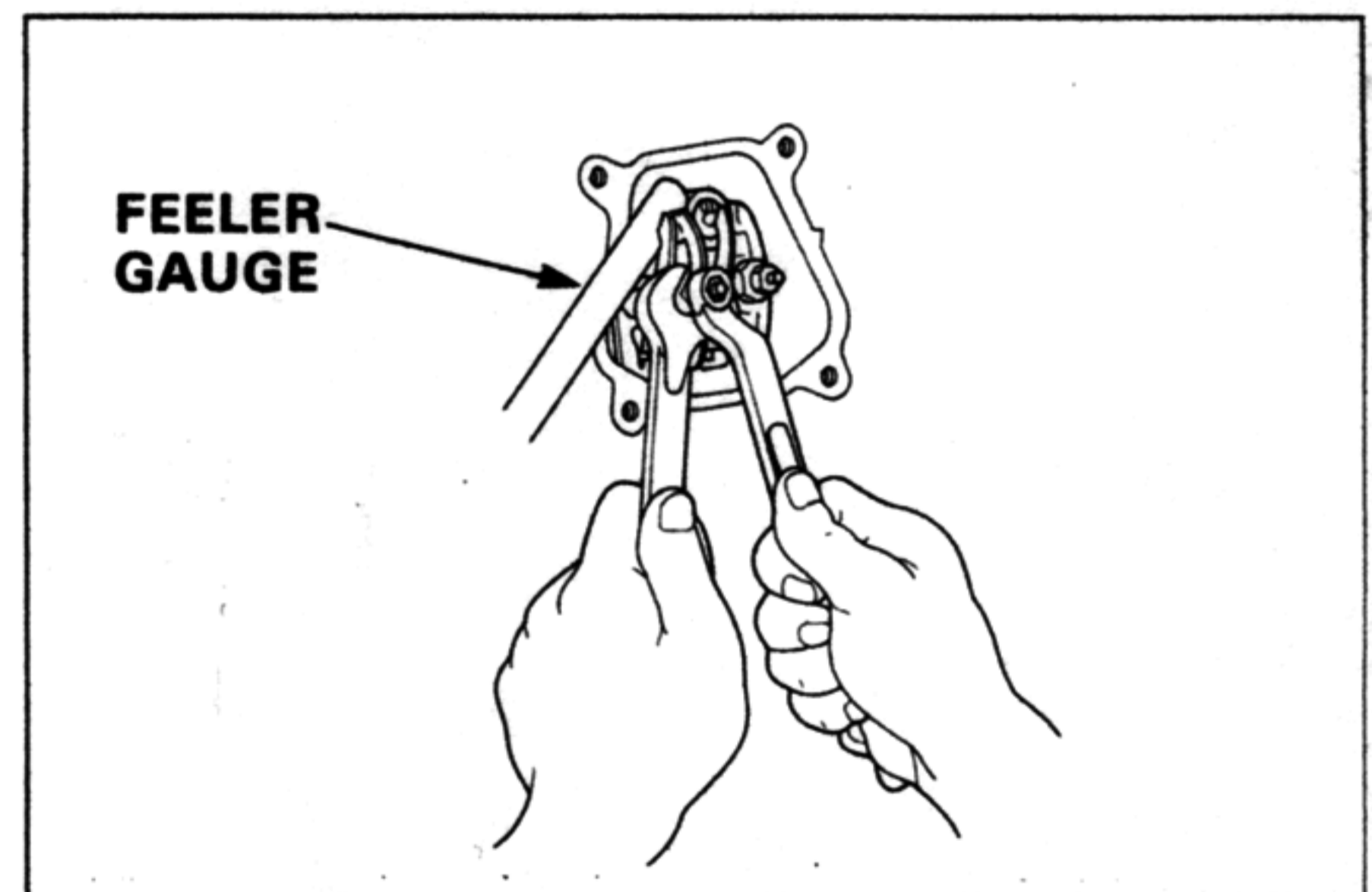

- 4) If adjustment is necessary, proceed as follows:
- Hold the rocker arm pivot and loosen the rocker arm pivot lock nut.
  - Turn the rocker arm pivot to obtain the specified clearance.
  - Retighten the rocker arm pivot lock nut while holding the rocker arm pivot.
  - Recheck valve clearance after tightening the rocker arm pivot lock nut.

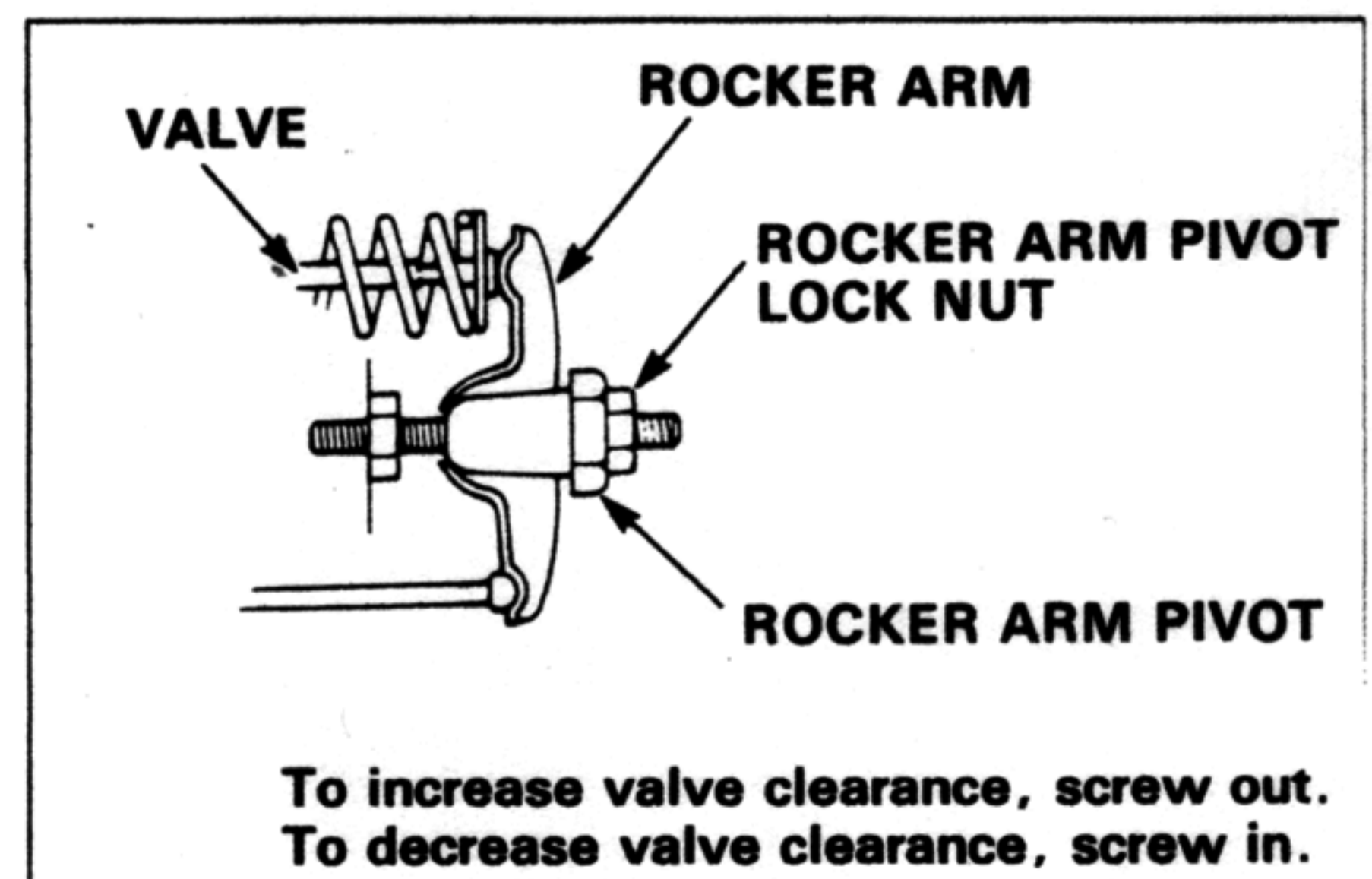

# VALVE CLEARANCE

**NOTE**

- Valve clearance inspection and adjustment must be performed with the engine cold.

1) Remove the cylinder head cover bolt, cylinder head cover and gasket.

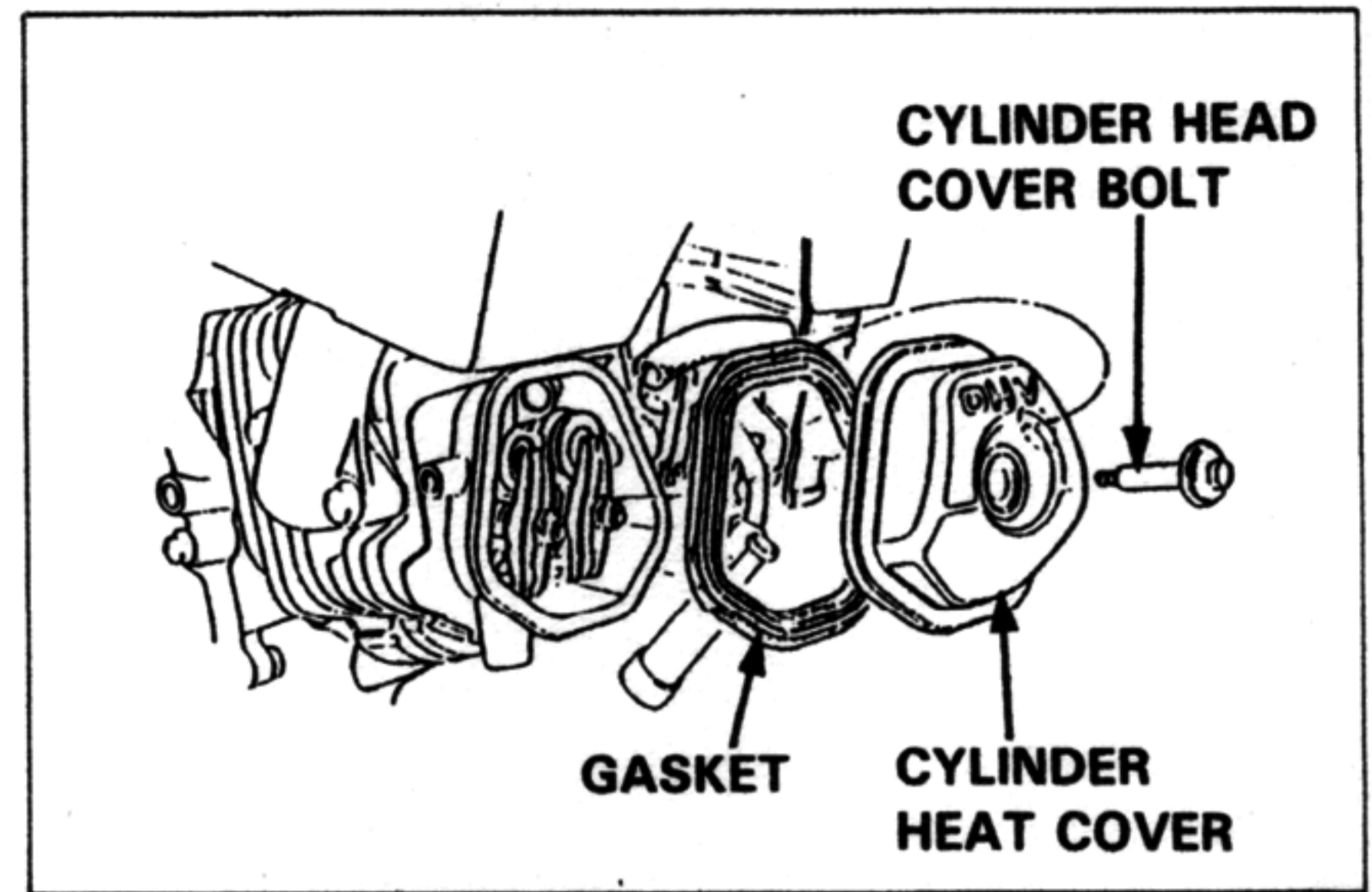

2) Set the piston at top dead center of the compression stroke (both valves fully closed). The triangular mark on the starter pulley will align with the top hole on the fan cover when the piston is at top dead center of the compression or exhaust stroke.

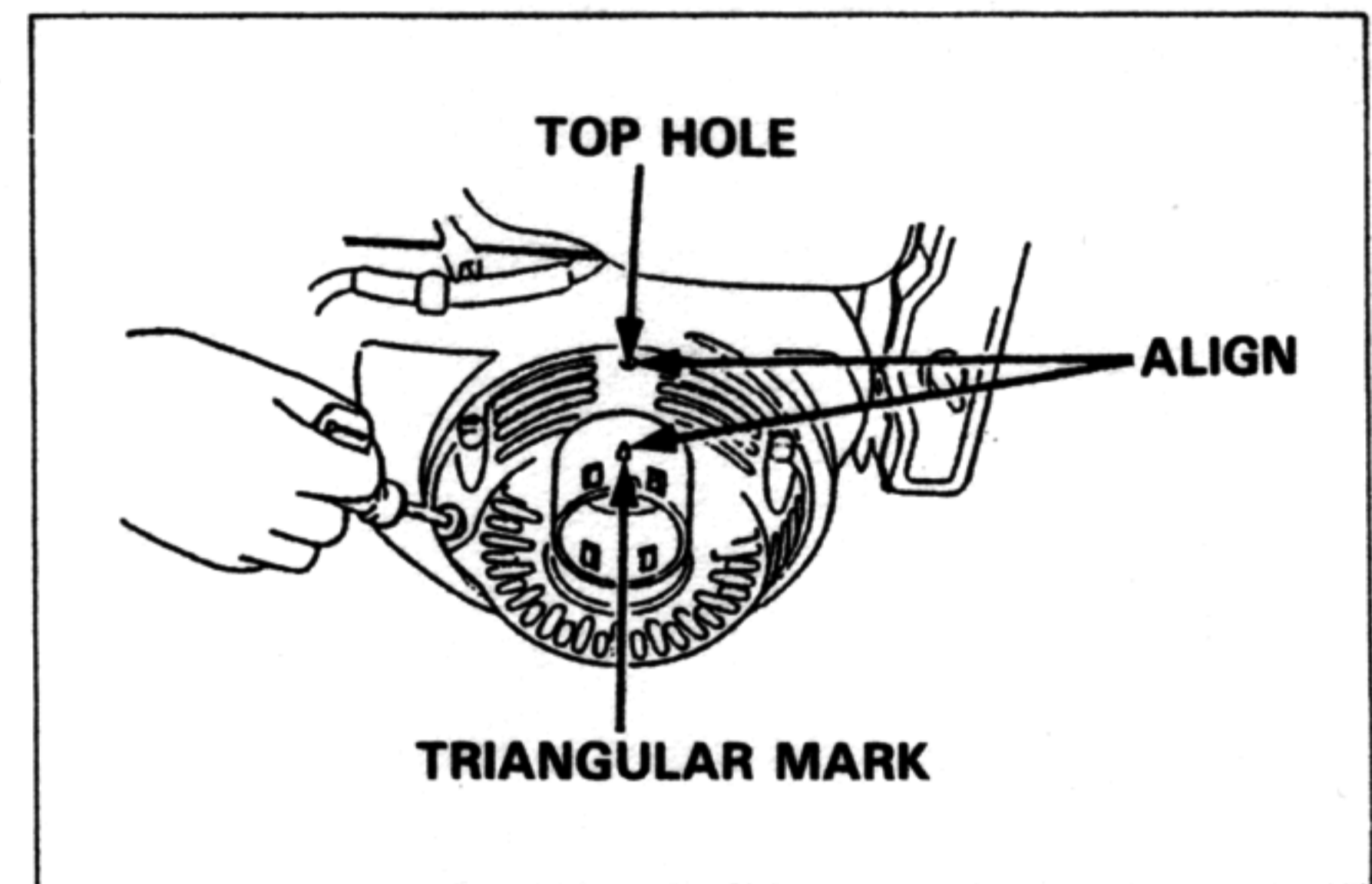

3) Insert a feeler gauge between the rocker arm and valve to measure valve clearance.

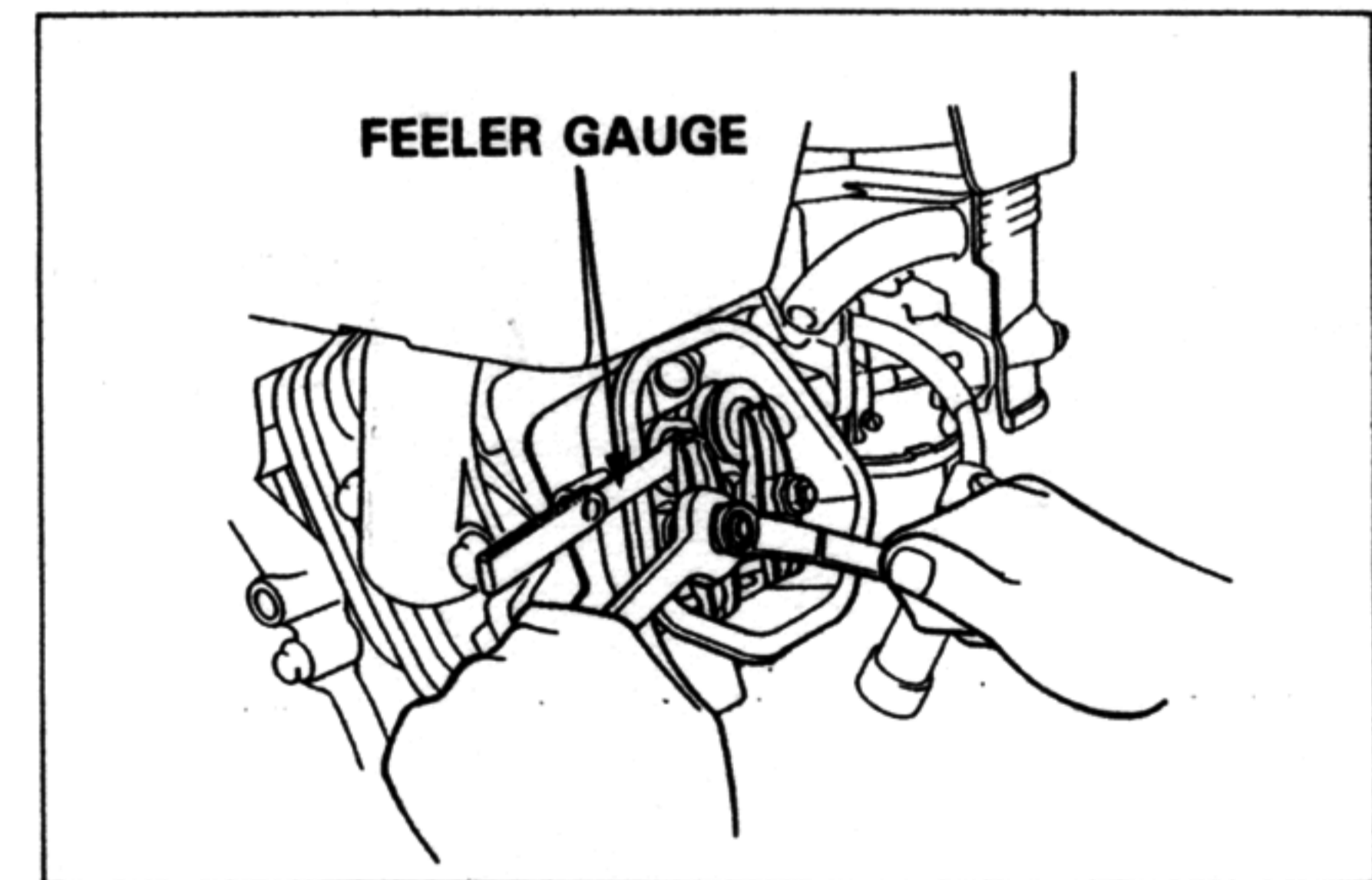

Standard valve clearance	IN	0.15 ± 0.02 mm (0.006 ± 0.001 in)
	EX	0.20 ± 0.02 mm (0.008 ± 0.001 in)

- 4) If adjustment is necessary, proceed as follows:
- Hold the rocker arm pivot and loosen the pivot lock nut.
  - Turn the rocker arm pivot to obtain the specified clearance.
  - Tighten the lock nut to the specified torque while holding the rocker arm pivot.
- TORQUE: 10 N·m (1.0 kg-m, 7 ft-lb)**
- Recheck valve clearance after tightening the lock nut.

