

# HONDA

GX240K1 · GX270  
GX340K1 · GX390K1

## ENGINE OIL

### • Oil alert

#### NOTE

- For convenience, perform this test in conjunction with the engine oil change.

- 1) With the engine running, disconnect the yellow lead from the engine switch, and ground the lead against the engine. The oil alert lamp should flash, and the engine should stop.
- 2) With the engine stopped, the crankcase filled with oil, and the oil level switch leads disconnected, check continuity between the yellow and green oil level switch leads. There should be no continuity.

### • Oil change

#### NOTE

- Drain the engine oil with the engine warm and in a horizontal position to assure complete and rapid draining.

- 3) With the engine stopped, remove the oil filler cap/dipstick and drain bolt. Allow the oil to drain completely.
- 4) With the oil switch leads disconnected, check continuity between the yellow and green oil level switch leads. There should be continuity.
- 5) Reinstall the drain bolt, and tighten it to specified torque.  
**TORQUE: 23 N·m (2.3 kg·m, 17 ft·lb)**
- 6) Fill the crankcase with the recommended engine oil to the outer edge of the oil filler neck.  
Reinstall the filler cap/dipstick.

Engine oil capacity	1.1 l (1.16 US qt, 0.97 Imp qt)
---------------------	---------------------------------

Use Honda 4-stroke oil or an equivalent high-detergent, premium quality motor oil certified to meet or exceed U.S. automobile manufacturer's requirements for Service Classification SG.SF/CC.CD. Motor oils classified SG.SF/CC.CD. will show this designation on the container. SAE 10W-30 is recommended for general, all temperature use. Other viscosities shown in the chart may be used when the average temperature in your area is within the indicated range.

#### CAUTION

- Do not overfill with engine oil.
- Check the engine oil with the engine positioned horizontally.
- Used engine oil may cause skin cancer if repeatedly left in contact with the skin for prolonged periods. Although this is unlikely unless you handle used oil on a daily basis, it is still advisable to thoroughly wash your hands with soap and water as soon as possible after handling used oil.

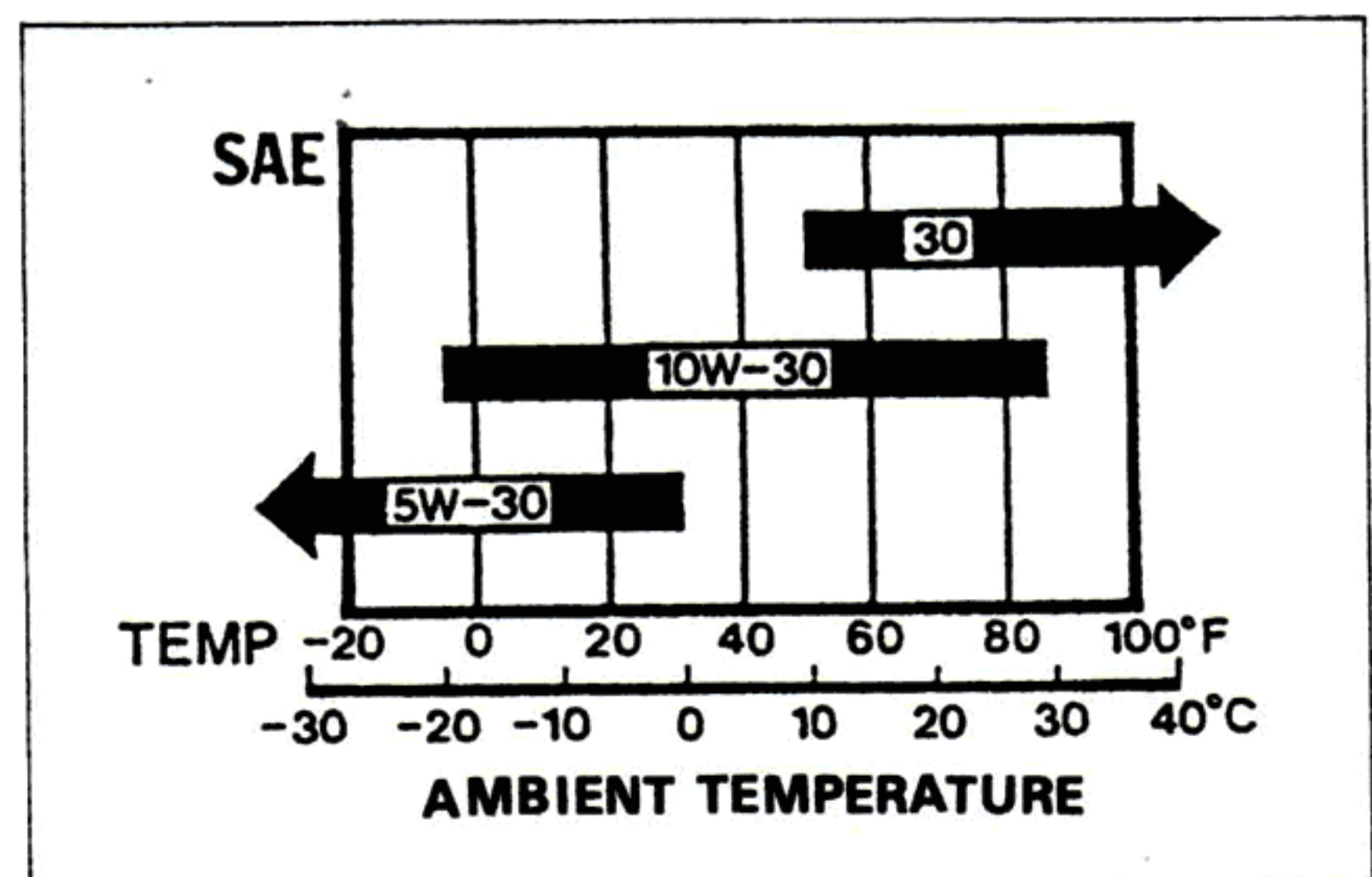
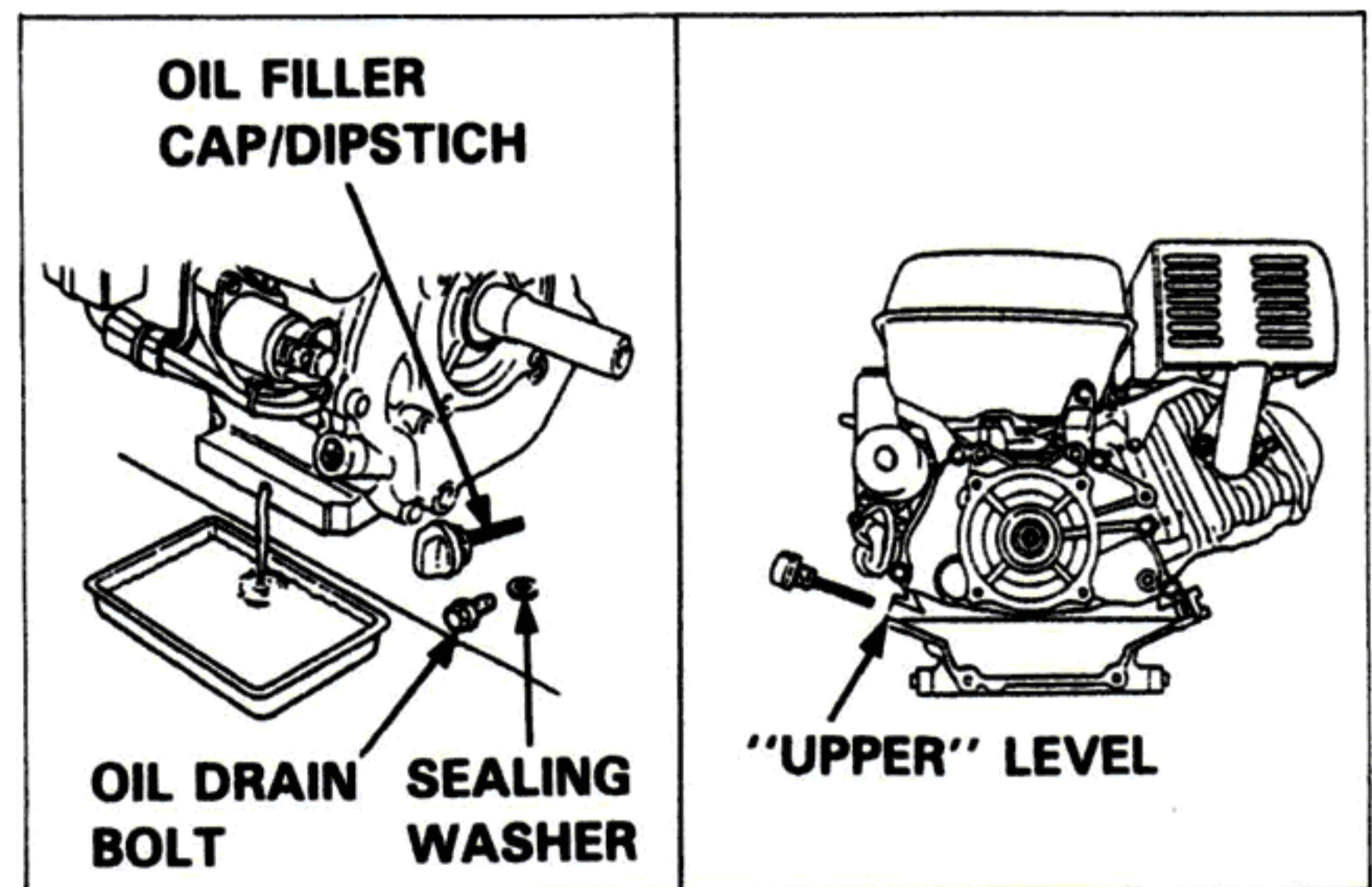
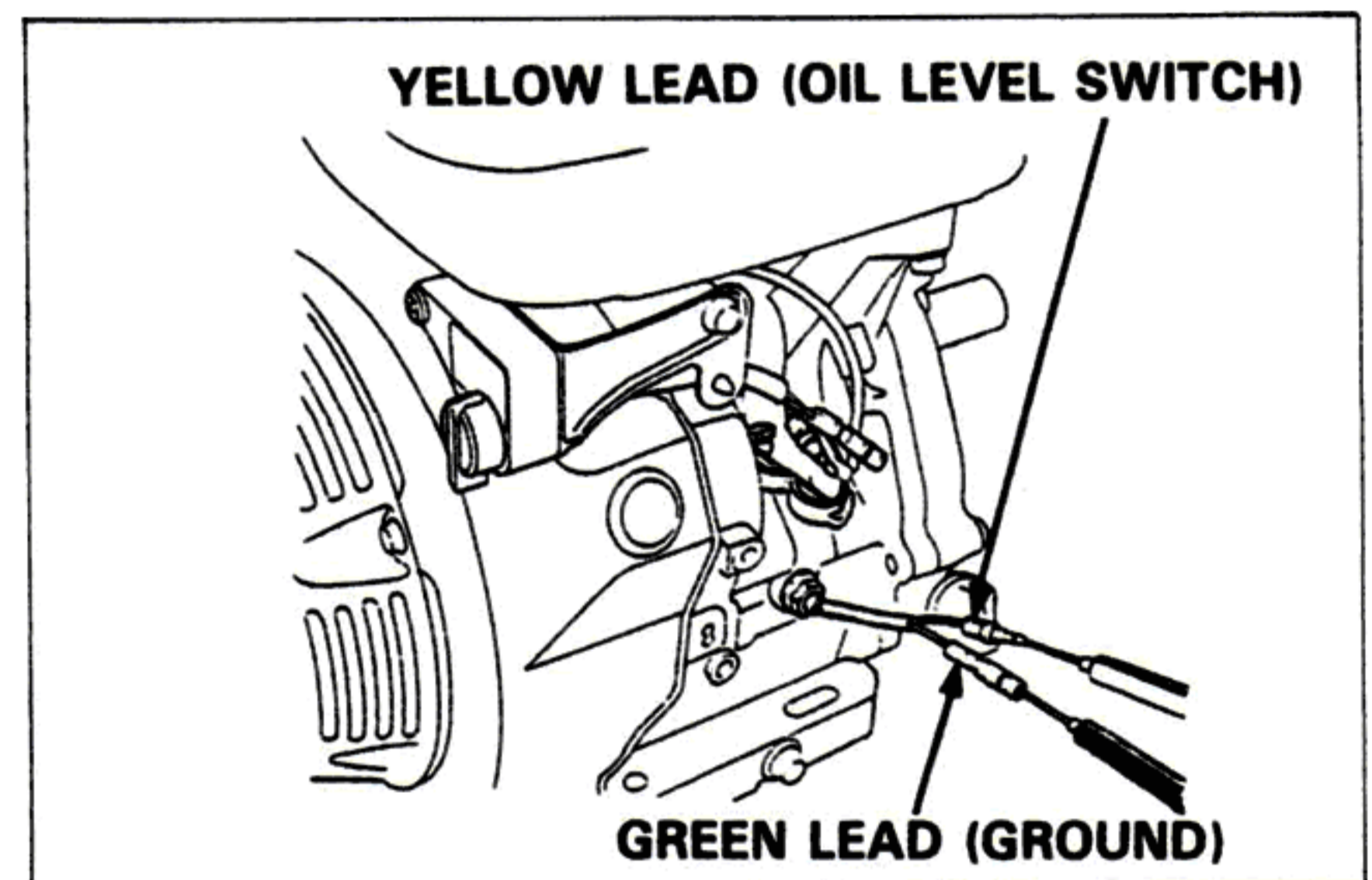
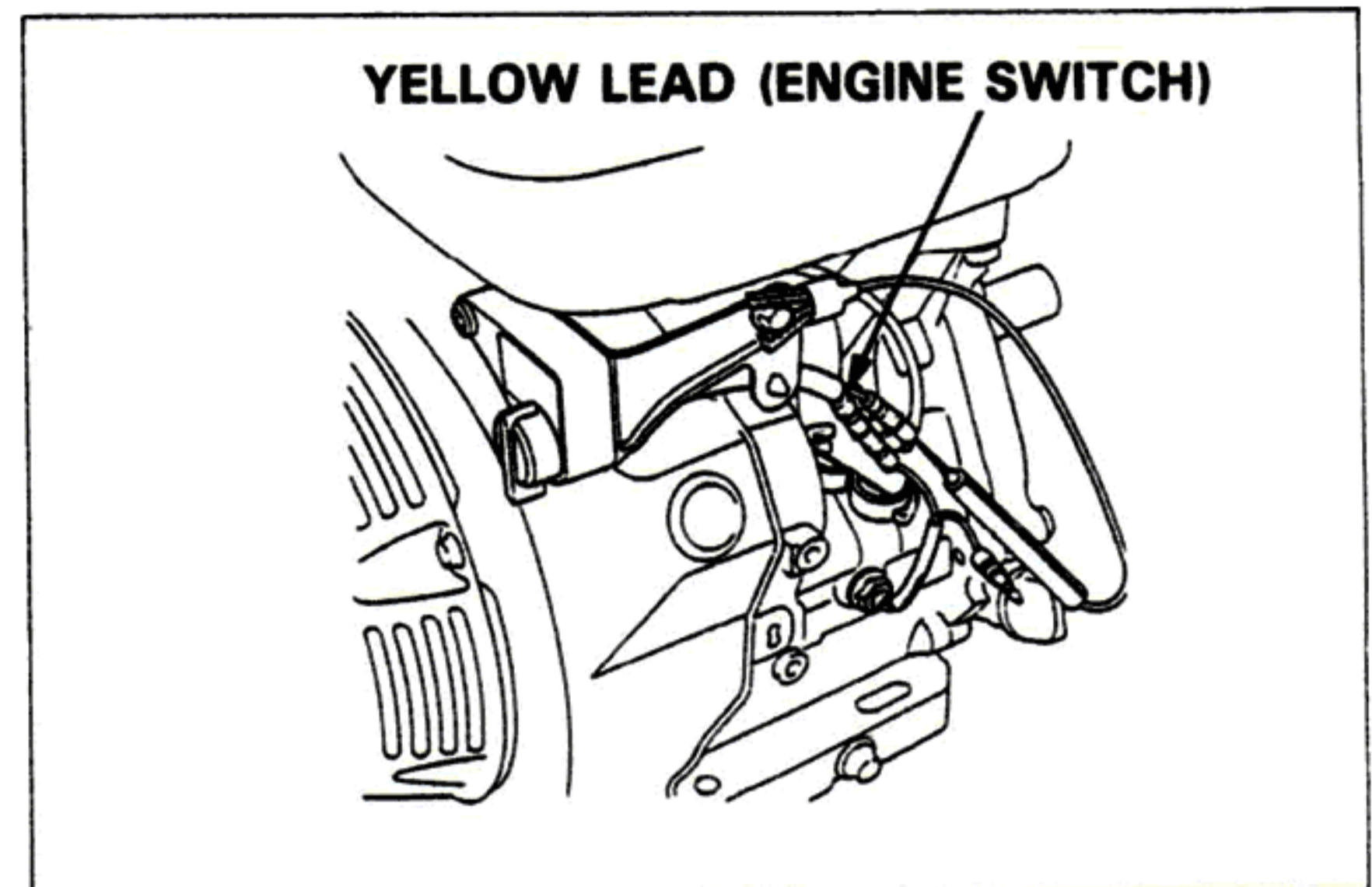

### ENGINE OIL

#### NOTE

• Change the engine oil with the engine warm and in a horizontal position to assure complete and rapid draining.

- 1) Remove the oil filler cap/dipstick and drain bolt. Allow the oil to drain completely.
- 2) Reinstall the drain bolt, and tighten it to specified torque.  
**TORQUE: 18 N·m (1.8 kg-m, 13 ft-lb)**
- 3) Fill the crankcase with the recommended engine oil to the outer edge of the oil filler neck. Reinstall the filler cap/dipstick.

Engine oil capacity	0.6 l (0.63 US qt, 0.53 Imp qt)
---------------------	---------------------------------

Use Honda 4-stroke oil or an equivalent high-detergent, premium quality motor oil certified to meet or exceed U.S. automobile manufacturer's requirements for Service Classification SG. SF/CC. CD. Motor oils classified SG. SF/CC. CD. will show this designation on the container. SAE 10W-30 is recommended for general, all-temperature use. Other viscosities shown in the chart may be used when the average temperature in your area is within the indicated range.

#### CAUTION

- Do not overfill with engine oil.
- Check the engine oil with the engine positioned horizontally.
- Used engine oil may cause skin cancer if repeatedly left in contact with the skin for prolonged periods. Although this is unlikely unless you handle used oil on a daily basis, it is still advisable to thoroughly wash your hands with soap and water as soon as possible after handling used oil.

### REDUCTION CASE OIL

1/2 Reduction (Centrifugal clutch type):

- 1) Remove the oil filler cap/dipstick, and drain bolt. Allow the oil to drain completely.
- 2) Reinstall the drain bolt, and tighten it to specified torque.  
**TORQUE: 18 N·m (1.8 kg-m, 13 ft-lb)**
- 3) Fill the reduction case with the same oil that is recommended for the engine. Fill to the upper limit mark on the dipstick.

OIL CAPACITY	0.5 l (0.53 US qt, 0.44 Imp qt)
--------------	---------------------------------

#### CAUTION

- Check the engine oil with the engine positioned horizontally.

1/6 Reduction:

- 1) Remove the filler bolt and oil level bolt. Tilt the engine to drain the used oil through the oil level bolt hole. Allow the oil to drain completely.
- 2) Stand the engine upright, and fill the reduction case with the same oil that is recommended for the engine. Fill until oil starts to flow from the oil level bolt hole.
- 3) Install the oil level bolt and filler bolt. Tighten them to the specified torque.

**TORQUE: 18 N·m (1.8 kg-m, 13 ft-lb)**

OIL CAPACITY	0.15 l (0.159 US qt, 0.132 Imp qt)
--------------	------------------------------------

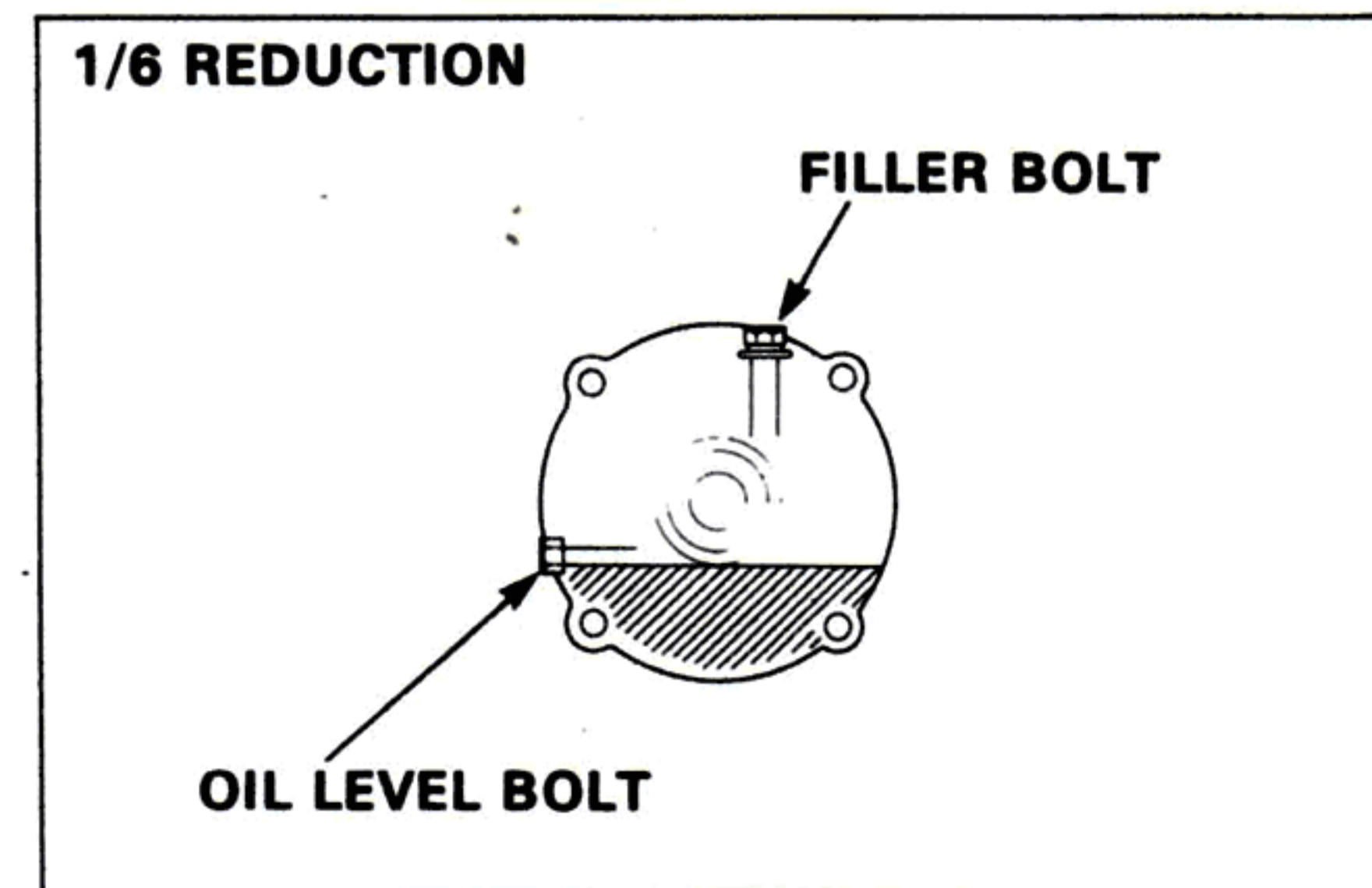
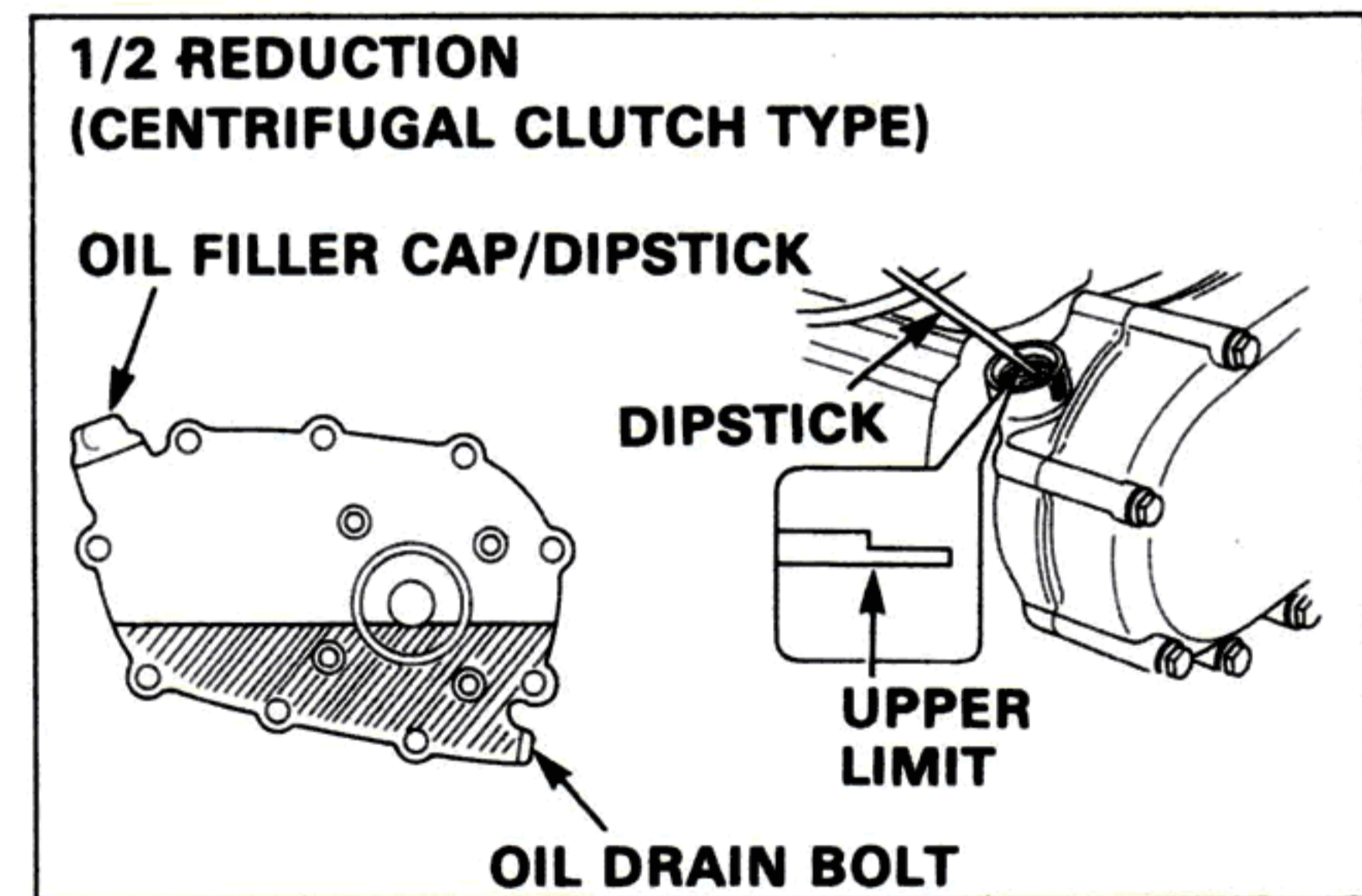
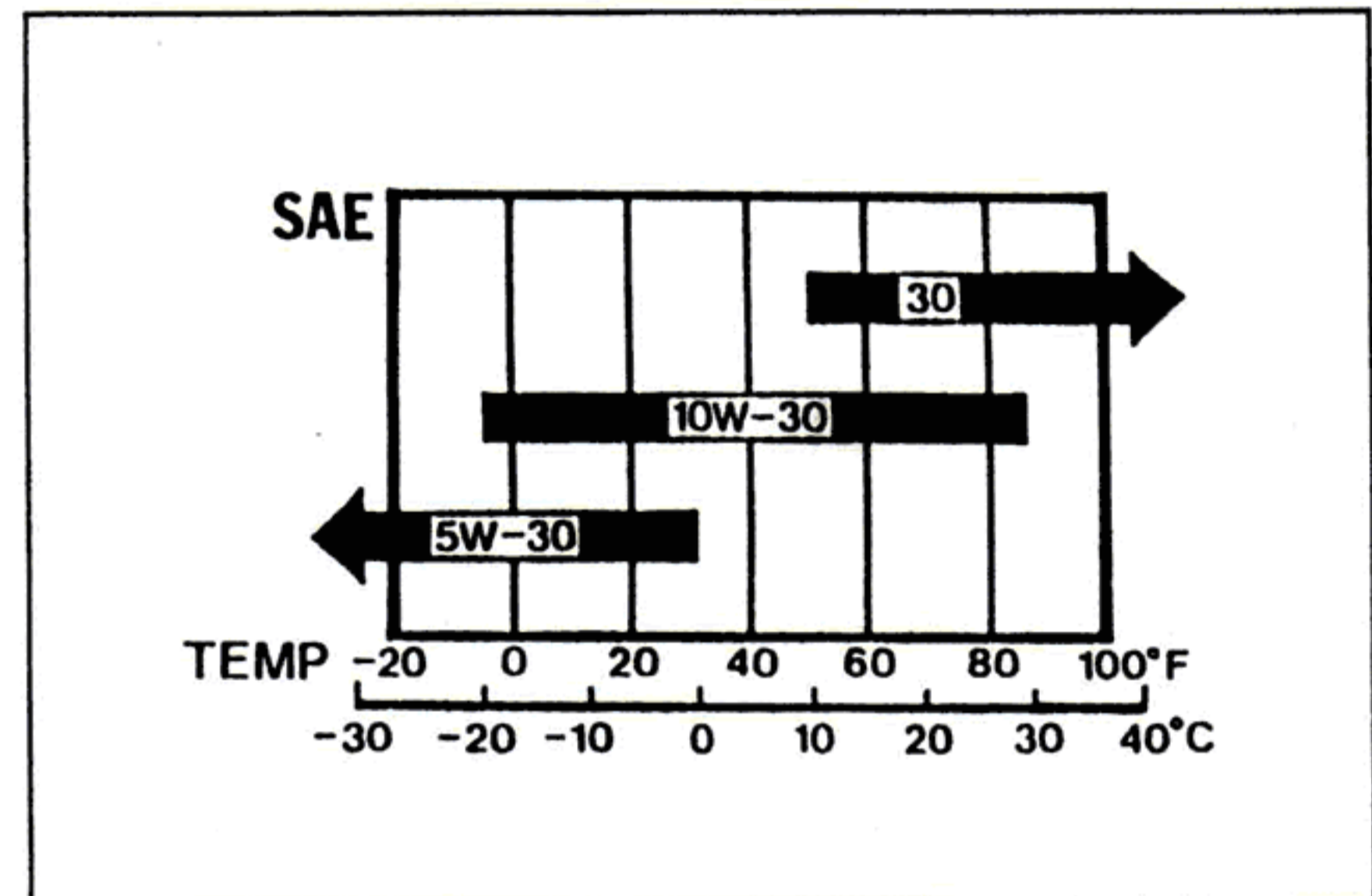
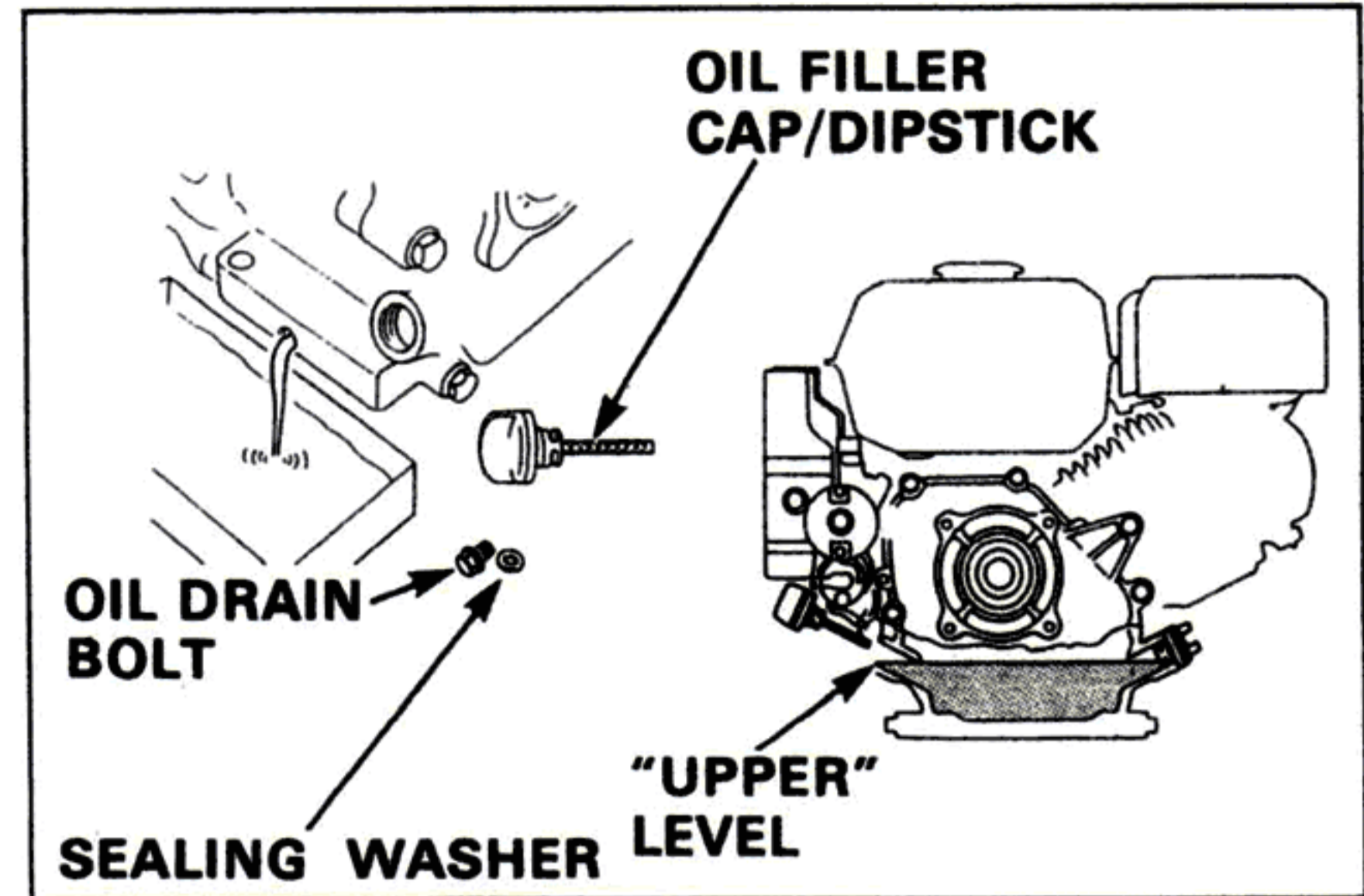

## REDUCTION CASE OIL (GX240K1, GX270 ONLY)

1/2 Reduction (Centrifugal clutch type):

- 1) Remove the oil filler cap/dipstick, and drain bolt. Allow the oil to drain completely.
- 2) Reinstall the drain bolt, and tighten it to specified torque.  
**TORQUE: 23 N·m (2.3 kg·m, 17 ft·lb)**
- 3) Fill the reduction case with the same oil that is recommended for the engine. Fill to the upper limit mark on the dipstick.

OIL CAPACITY	0.3 l (0.32 US qt, 0.26 Imp qt)
--------------	---------------------------------

### CAUTION

- Check the engine oil with the engine positioned horizontally.

### NOTE

- 1/2 Reduction (without centrifugal clutch type) and 1/6 reduction are lubricated from engine crankcase.

## AIR CLEANER

### ⚠ WARNING

- Never use gasoline or low flash point solvents for cleaning the air cleaner element. A fire or explosion could result.

Dual element, silent, cyclone type:

- 1) Remove the nut, air cleaner cover and wing nut. Remove the air cleaner elements and separate them. Carefully check both elements for holes or tears and replace if damaged.
- 2) Foam element: Clean in warm soapy water, rinse and allow to dry thoroughly. Or clean in high flash point solvent and allow to dry. Dip the element in clean engine oil and squeeze out all the excess. The engine will smoke during initial start-up if too much oil is left in the foam.
- 3) Paper element: Tap the element lightly several times on a hard surface to remove excess dirt or blow compressed air lightly (30 psi or less) through the filter from the inside out. Never try to brush the dirt off; brushing will force dirt into the fibers.
- 4) Wash the paper element with clean, high flash point solvent.
  - If you are using a parts washer with a recirculating stream of solvent, direct the stream at the inside of the element. Do not use equipment that delivers solvent under high pressure.
  - If you are using a container filled with solvent, immerse the filter and agitate it. Do not use a brush to clean the filter.

### 1/2 REDUCTION (CENTRIFUGAL CLUTCH TYPE)

OIL FILLER CAP/DIPSTICK

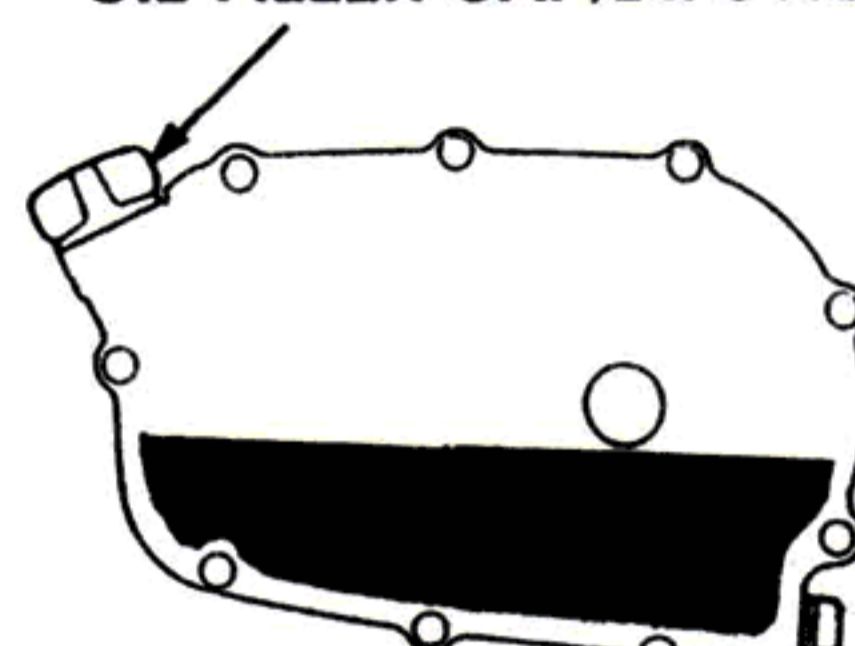

OIL DRAIN BOLT

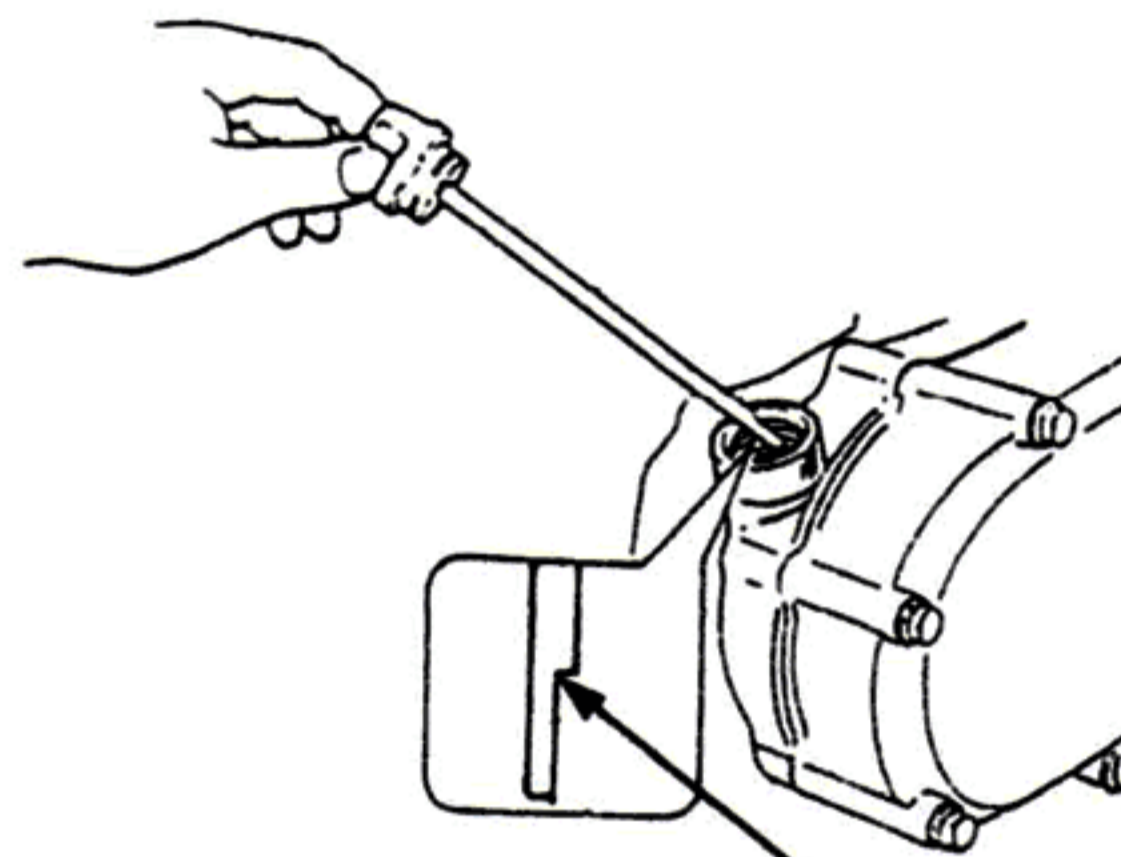

UPPER LIMIT

### SILENT TYPE:

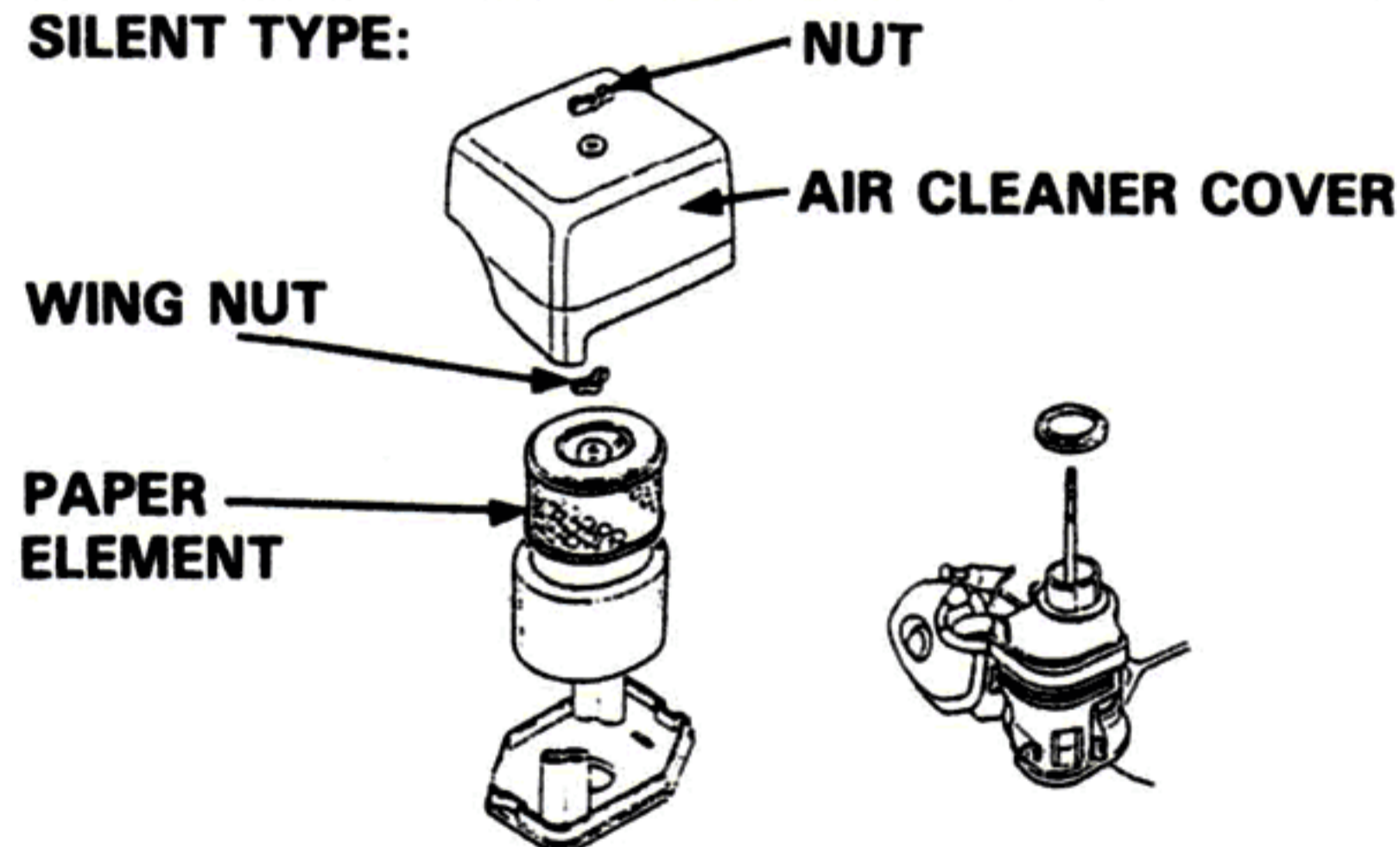

### CYCLONE TYPE:

